

SIEMENS



Synco™ 700 **Bus Operator Unit RMZ792** **Basic Documentation**



Edition 1.0
Series A
CE1P3113en
03.04.2006

Building Technologies
HVAC Products

Siemens Switzerland Ltd
Building Technologies Group
International Headquarters
HVAC Products
Gubelstrasse 22
CH- 6301 Zug
Tel. +41 41 724 24 24
Fax +41 41 724 35 22
www.sbt.siemens.com

© 2006 Siemens Switzerland Ltd
Subject to alteration

Contents

1	Summary	7
1.1	Bus operator unit RMZ792	7
1.2	Operator units	7
1.3	Topology of Synco™ 700	8
1.4	Product documentation	8
1.5	Key features	9
1.6	Important notes	10
2	Operation	11
2.1	Functions of the bus operator unit	11
2.2	Operating concept	11
2.3	Operating levels	12
2.4	Menu tree	13
3	Operation of devices	15
3.1	Product range	15
3.2	Remote operation and local operation	15
3.3	Navigating on the device list	15
3.4	Quick access with favorites	16
3.5	Information describing what is visible	16
3.6	Error handling	16
3.7	User-defined text	17
4	Power supply	18
4.1	Power supply via Konnex bus	18
4.2	External power supply	18
4.3	Power supply via Synco™ controller	19
4.4	Error handling	19
5	Commissioning	20
5.1	Entering the commissioning mode	20
5.1.1	Entry on first startup	20
5.1.2	Entry from the main menu	20
5.2	Leaving the password level	20
6	“Commissioning” menu	21
6.1	Device address	21
6.1.1	Automatic address search	21
6.1.2	Manual assignment of addresses	21
6.1.3	Address assignment with the ETS	21
6.1.4	Error handling	22

6.2	Activating communication	22
6.2.1	Submenu "Communication"	22
6.3	Device list.....	23
6.3.1	Submenu "Create list"	24
6.3.2	Submenu "Sort list"	24
6.3.3	Submenu "Name devices"	25
6.3.4	Submenu "Add devices".....	26
6.3.5	Submenu "Delete devices".....	26
6.3.6	Submenu "Delete list"	26
6.3.7	Submenu "Display list".....	27
6.3.8	Submenu "List information".....	27
6.4	Favorites	27
6.4.1	Submenu "Add datapoints"	28
6.4.2	Submenu "Name datapoints"	29
6.4.3	Submenu "Name favorites".....	29
6.4.4	Submenu "Sort favorites"	29
6.4.5	Submenu "Delete datapoints"	30
6.4.6	Submenu "Delete favorites"	30
6.4.7	Submenu "Delete all favorites".....	31
7	Data backup.....	32
7.1	Local data backup.....	32
7.2	Data backup on a second unit	33
7.3	Error handling	34
8	General settings.....	35
8.1	Time of day and date	35
8.1.1	Format.....	35
8.1.2	Setting.....	35
8.1.3	Error handling	36
8.2	Selecting the language	36
8.3	Selecting the unit of temperature	37
8.4	Contrast of display on the operator unit	37
8.5	Display of bus fault status messages.....	37
8.6	Text entries	37
8.7	Password	38
8.8	Device list.....	38
8.9	Favorite pages	38
9	Device information	39
10	Faults	40
10.1	Display of faults.....	40

10.1.1	Device list on the “Main menu”	41
10.1.2	Menu “Faults current”	41
10.1.3	Info page and menu “Fault status message bus”	41
10.2	Faults of non-listed bus users.....	41
10.3	Acknowledgement of faults.....	42
10.4	Resetting faults.....	42
10.5	Deleting faults.....	42
11	Memory card.....	43
11.1	Content of memory card	43
11.2	Exchanging the memory card.....	43
12	Support in the event of errors and faults	44
12.1	Error code list	44
12.2	Rectification of errors.....	44
13	Electrical connections.....	46
14	Appendix.....	47
14.1	Abbreviations used in this document.....	47
14.2	Editable text.....	47

1 Summary

1.1 Bus operator unit RMZ792

What is the RMZ792 bus operator unit?

The RMZ792 is a communicating operator unit designed for operating Synco™ 700 devices in a Konnex network. The operator unit is suited both for fixed installation and mobile use (e.g. for use by the service engineer).
Third-party devices cannot be operated with it.

Konnex makes it possible

Thanks to the Konnex bus, the bus operator unit can access all Synco™ controllers installed in the network.

User-friendly at all levels

Whether for endusers, engineering, service or commissioning staff, menu-driven operation in clear-text underlines the system's user-friendliness at all levels.
The RMZ790 and RMZ791 controller operator units and the RMZ792 bus operator unit use identical operating elements and are based on the same Synco™ operating philosophy.



Functions



- Operation of up to 150 devices
- Suited for use with controllers, room units and central units of the Synco™ 700 product family
- Operation of RXB... and RXL... individual room controllers communicating via Konnex
- Automatic device search run within the line / area
- Access to the user and service levels
- Display and acknowledgement of faults from all bus users
- Freely definable passwords for all access levels
- 20 user-defined favorite pages
- Power supply via Konnex bus or external AC 24 V power supply
- Straightforward upgrading of languages, text catalog and device descriptions by means of plug-in type memory card
- Fixed installation or mobile use

1.2 Operator units

Operator units and accessories

Synco™ plant can be operated with various types of operator units. They are distinguished by design, the number of devices that can be handled by them, the scope of functions, the kind of usage and location:

<i>Name</i>	<i>Illustration</i>	<i>Function</i>	<i>Type reference</i>	<i>Data Sheet no.</i>
Bus operator unit		Bus operation for service staff and users, without commissioning functions	RMZ792	N3113
Memory card for bus operator unit		Device descriptions and language catalogs for the bus operator unit	RMA792	N3113
Operator unit, plug-in type		Local operation for commissioning, service and users	RMZ790	N3111

Name	Illustration	Function	Type reference	Data Sheet no.
Operator unit, detached		Local operation for commissioning, service and users	RMZ791	N3112
Service and operator unit		PC software for commissioning, service and users	OCI700.1	N5655

1.3 Topology of Synco™ 700

Use of the RMZ792 bus operator unit

The illustration below shows a typical topology for using the RMZ792 bus operator unit:

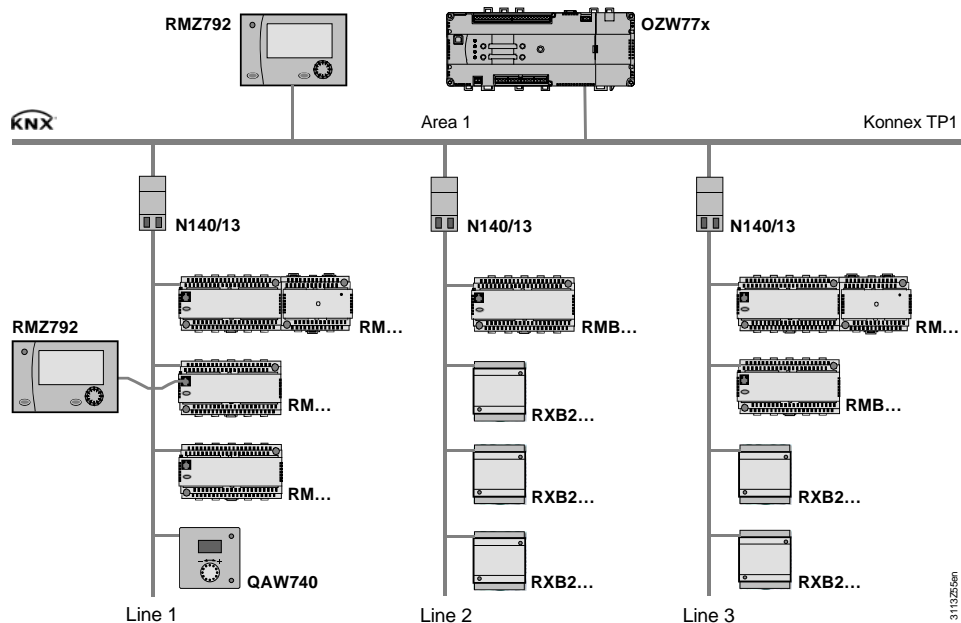

- RM... Synco™ 700 controllers
- RMB... Central control units
- RXB2... Individual room controllers
- OZW77... Central communication unit
- QAW740 Room unit
- N140/13 Line / area coupler

The bus operator unit is used for operating Synco™ devices within a single line or for a plant consisting of several lines. Synco™ devices in neighboring lines or areas can always be accessed, independent of the unit's location. To keep bus loading at the lowest possible level, it is recommended to install the operator unit within the line or area of the relevant bus users wherever possible.

1.4 Product documentation

In addition to the present Basic Documentation, the product documents listed below provide detailed information about the safe and correct deployment and operation of Synco™ 700 products in building services plant.

<i>Type of document</i>	<i>Document no.</i>
Data Sheet "Bus Operator Unit RMZ792"	N3113
Installation Instructions "Bus Operator Unit RMZ792"	G3113
Environmental Declaration "Bus Operator Unit RMZ792"	E3113
Product range description "HVAC controllers with Konnex interface"	S3110
Basic Documentation "Communication with Konnex bus"	P3127
Data Sheet "Konnex bus KNX"	N3127
Synco™ 200 / Synco™ 700 Valid Version Set	J3100
CE Declaration of Conformity Synco 700	T3110

1.5 Key features

Overview of outfit and functions of the RMZ792 bus operator unit:

<i>Outfit / functions</i>	<i>RMZ792</i>
Operating elements	
Select-and-press knob (OK knob)	✓
Info button to display information about the plant	✓
Fault button for optical indication and acknowledgement	✓
Backlit LCD (128x64 picture points)	✓
Operation	
Menu-driven operation in clear-text	✓
Access levels	3
Password protection for each access level	✓
Handling faults	
Info page with clear-text display of faults	✓
Visualization of faults with red LED	✓
Display of all faulty devices with fault symbol	✓
Remote acknowledgement and resetting of faults	✓
Display of simultaneous faults (fault list)	20
Maximum number of bus users	150
User-defined favorite pages	
Number of favorite pages	20
Number of datapoints per favorite page	10
Functions	
Automatic device search run	✓
Manual adding / removal of devices	✓
Automatic / manual sorting of device list	✓
Naming devices	✓
Adding / removing / naming / sorting favorites	✓
Exchangeable memory card (languages, device information)	✓
Power supply	
Konnex bus	✓
Externally, AC 24 V	✓

Note

The following operating functions cannot be performed from the bus operator unit:

- Access to the datapoints on the password level of the bus users (e.g. commissioning)
- Display of trend graphs
- Deletion of fault history

1.6 Important notes



This symbol shall draw your attention to special safety notes and warnings. If such notes are not observed, personal injury and / or considerable damage to property can occur.

Field of use	Synco™ 700 products may only be used for the control and supervision of heating, ventilation, air conditioning and chilled water plant.
Proper use	Prerequisites for flawless and safe operation of Synco™ 700 products are proper transport, installation and commissioning, as well as correct operation.
Electrical installation	Fuses, switches, wiring and earthing must be in compliance with local safety regulations for electrical installations.
Commissioning	Preparation for use and commissioning of Synco™ 700 products must be undertaken by qualified staff who have been appropriately trained by SBT HVAC Products.
Operation	Synco™ 700 products may only be operated by staff who have been instructed by SBT HVAC Products or their delegates and whose attention has been drawn to potential risks.
Wiring	When wiring the system, the AC 230 V section must be strictly segregated from the AC 24 V safety extra low-voltage (SELV) section in order to ensure protection against electric shock hazard!
Storage and transport	For storage and transport, the limits given in the relevant Data Sheets must always be observed. If in doubt, contact your supplier or SBT HVAC Products.
Maintenance	Synco™ 700 products are maintenance-free, apart from cleaning at regular intervals. System sections accommodated in the control panel should be freed from dust and dirt whenever normal service visits are due.
Faults	Should system faults occur and you are not authorized to make diagnostics and to rectify faults, call your Siemens customer service.
	 Only authorized staff are permitted to make diagnostics, to rectify faults and to restart the plant. This also applies to work carried out within the control panel (e.g. safety checks or replacement of fuses).
Disposal	The products contain electrical and electronic components and must not be disposed of as domestic waste. Local and currently valid legislation must be observed

2 Operation



Synco™ 700 devices may only be operated by staff who have been instructed by SBT HVAC Products or their delegates and whose attention has been drawn to potential risks.

2.1 Functions of the bus operator unit

The RMZ792 bus operator unit is used to make all settings and readouts required for operating a device. All entries made on the bus operator unit are transmitted to the respective device where they are handled and stored; the operator unit itself does not store any data. The information required by the user is generated by the devices and transmitted to the operator unit for display. The text catalog in different languages and the description of the operating structure of all operable Synco™ 700 devices are stored locally on the exchangeable memory card (RMA792) in the operator unit.

2.2 Operating concept

General

On the software side, all settings and readout values are arranged as datapoints (operating lines) of the menu tree. Using the operating elements, every datapoint can be selected, displayed or set. All menus appear on the LCD as clear-text.

The bus operator unit has several languages preprogrammed; when commissioning the plant, the required language must be activated. The Operating Instructions for the user are integrated in the Installation Instructions (G3113).

Operating elements

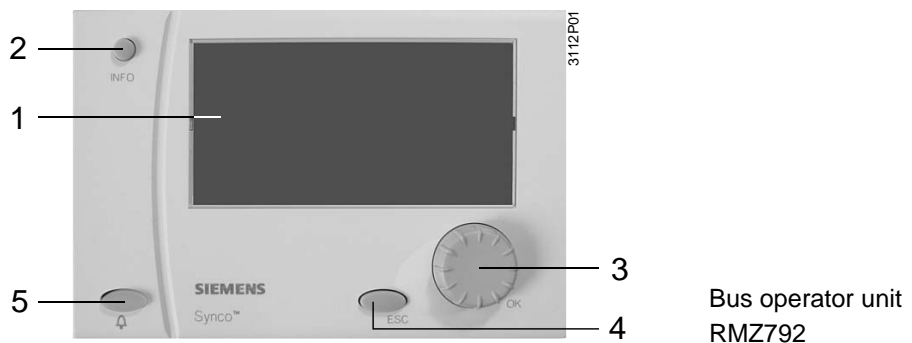

- 1 Display
- 2 INFO button
 - Function 1: Display of key plant data
 - Function 2: Display of information about the individual datapoints on the current menu
- 3 OK select-and-push knob
 - Turn: Selection of operating line or readjustment of value
 - Press: Confirmation of operating line or setting
- 4 ESC button
 - Going back to the previous menu
 - Canceling readjustment of value
- 5 Fault button “” with LED
 - LED: Indication of fault
 - Press: Acknowledgement of fault or reset

When one of the operating elements is operated, the backlit display will automatically be switched on. If there is no operation for 30 minutes, it will be switch off again and the start page appears. In the event of pending faults, the fault information page is displayed in place of the start page.

Display examples



Start page



Device list, partly with fault symbol



Pop-up, setting a numerical value

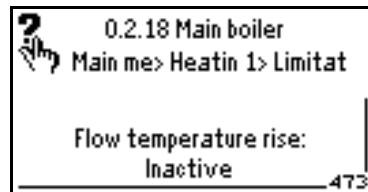

Help picture with explanations relating to the selected setting parameter

2.3 Operating levels

The following operating levels are available:

Level	Icon	Description
Info level		On the info level, important plant data (fault and service information) can be retrieved and displayed. No values can be changed here. The info level can be accessed at any time and is not password-protected.
User level		The user level is made up in the form of a menu tree. Here, datapoints can be read and / or their values changed. The user level can be protected by a password to prevent unauthorized access. The bus operator unit is supplied with no password protection activated. From this level, the user level of the bus users can be accessed.
Service level		The Service level provides access to other menus and datapoints of the bus operator unit. The service level of the bus operator unit can be protected by a password to prevent unauthorized access. The unit is supplied with no password protection activated. From this level, the service level of the bus users can be accessed, e.g. for setting parameters or for plant maintenance.

<i>Level</i>	<i>Icon</i>	<i>Description</i>
Password level		The password level displays additional menus and datapoints for configuring and commissioning the bus operator unit. The password level is protected by a password to prevent unauthorized access. The unit comes standard with number "7" as the password. From this level, the password level of the bus users cannot be accessed; the setting only acts locally.

With the exception of the info level, operation is structured in the form of a menu tree. Individual menus or operating lines are enabled depending on the access level. The higher access level always displays all menus and operating lines of lower access levels also; the password level shows the entire menu tree. The active level is indicated by an appropriate symbol at top left.

Using the INFO button, explanations relating to the menus and the individual datapoints can be displayed. The information is displayed as long as the button is kept depressed.

Switching between operating levels

Switching to the info level:

1. Press the ESC button repeatedly until the start page reappears.
2. Press the INFO button or turn the OK knob to change to the info level.
3. To navigate within the info pages, press the INFO button repeatedly **or** turn the OK knob.

Switching to the user level:

1. Selecting the start page: Press the ESC button repeatedly until the start page reappears.
2. Press the OK knob.
3. If the user level is password-protected, the Access levels menu appears now.
4. Select the User level by turning the OK knob.
5. Enter the password required for the respective access level.
6. Press the OK knob to confirm the password.

Switching to the service level or password level:

1. Selecting the start page: Press the button repeatedly until the start page reappears.
2. Press the OK knob and the ESC button simultaneously. The Access levels menu appears.
3. Select the required access level by turning the OK knob and confirm by pressing the knob.
4. If necessary, enter the password required for the respective access level.
5. Press the OK knob to confirm the password.

If there is no operating action for 30 minutes, the unit will automatically change to the start page and the user level.

2.4 Menu tree

The menu tree of the bus operator unit is divided into 3 types of menus:

1. **Info:**
Values cannot be changed. The pages are on the info level and cannot be protected by a password.
2. **Devices:**
Device list with all bus users. The menu tree of the respective bus user can be opened via the user's device name.
Alternatively, the most important and most frequently used datapoints of bus users can be accessed via user-defined favorite menus.

The datapoints can be displayed or changed. Optionally, the menus can be protected by a password (user level) to prevent unauthorized access.

3. **Local menus:**

All settings of the bus operator unit are made on the local menus. The settings are not valid for bus users on the device list. The menus appear in accordance with the operating level currently used and are protected by the passwords of the service and password levels.

Type	Menu name	Functions	Range of action
1. Info	Fault status signal bus...	Plant operating state	Read access only No password protection
	Service information...	Business card	
2. Devices	Favorites...	User-definable menus with the most important values	Synco bus users Read and write access Password protection (optional)
	Device name 1 Device name 2 ... Device name(s) ...	Device list: Access to devices 1...n	
3. Local menus	Commissioning...	Settings for communication	RMZ792 local Partly with password protection
		Makeup and format of device list	
		Makeup and contents of favorite pages	
	Device list...	Presentation of device list	
	Favorite pages...	Presentation of favorite pages	
	Time of day / date...	Settings of time of day and date	
	Faults...	Display of current faults and of faults on the bus	
	Settings...	Settings, such as language, passwords and texts	
	Device information...	Device information, such as hardware and software versions	
	Data backup...	Storing and retrieving settings	

3 Operation of devices

3.1 Product range

The RMZ792 bus operator unit is used for operating the following devices of the Synco™ family (situation February 2006):

Type of unit	Type reference	Data Sheet no.
Central control unit	RMB795...	N3121
Heating controllers	RMH760...	N3131 and N3133
Boiler sequence controller	RMK770...	N3132
Switching and monitoring device	RMS705...	N3123
Universal controllers	RMU710... RMU720... RMU730...	N3144 N3144 N3144
Room controllers RXB...	RXB21.1/FC-09 RXB21.1/FC-10 RXB21.1/FC-11 RXB22.1/FC-08 RXB22.1/FC-12	N3872 N3873 N3873 N3872 N3873
Room controllers RXL...	RXL21.1/FC-10 RXL21.1/FC-11 RXL22.1/FC-12	N3877 N3877 N3877
Room unit for Synco™ 700 controller	QAW740	N1633
Central communication units	OZW771... OZW775...	N3117 N5663



To ensure trouble-free functioning of the bus operator unit, compatible software versions of the different types of communicating units must be combined. For compatible units and versions, refer to document J3100 (Synco™ 200 / Synco™ 700 Valid Version Set).

3.2 Remote operation and local operation

The bus operator unit provides access to the datapoints of the bus users' user and service levels. But the datapoints of the bus users' password level are to be accessed via the local RMZ790 and RMZ791 operator units. For this reason, the RMZ792 bus operator unit cannot be used for configuring and commissioning plant.

3.3 Navigating on the device list



During commissioning, the device list (list containing all bus users) is generated. Data-points are always to be accessed via the device list – with the exception of the favorite pages (refer to section 3.4 “Quick access with favorites”). By selecting the required unit from the device list, the operator reaches the menu tree of the unit needed.

Menu tree and navigation are not any different from local operation with the RMZ790 or RMZ791.

When pressing the INFO button during navigation, the following information is displayed:

- The device name and – if appropriately set – the device address
 - The current position in the menu tree (path)
 - Long text relating to the selected datapoint
- The information is displayed as long as the button is kept depressed.

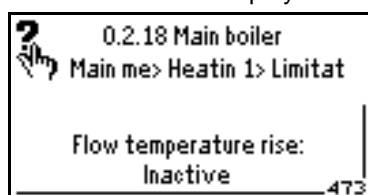

3.4 Quick access with favorites



The favorite pages provide a user interface matched to the requirements of every day use. On the favorite pages, simple datapoints of any devices from the device list can be combined. From their location in the menu tree of the respective device, the datapoints are copied to the required favorite page. This makes navigation much more efficient. All favorite pages are identified by the ♥ symbol in the corner at top right. This makes it easy to distinguish between favorite pages and the unit's menu tree.

3.5 Information describing what is visible

Certain Synco devices deliver information that describes what is visible. When using this information, the user interface only displays datapoints that are important for the controller's current configuration.

If a device does not support this kind of information, the bus operator unit will display all available datapoints – independent of the device's configuration. For this reason, datapoints may assume values that do not make sense and setting values may not trigger any actions because the device's current configuration does not support them or they are inactive.

The following types of devices do not contain information describing what is visible:

Type of device	Type reference
Room controller	RXB..., RXL...
Central communication unit	OZW771...
Central communication unit	OZW775...
Room unit for Synco™ 700 controller	QAW740

3.6 Error handling

Possible cases

Error / error message	Cause / remedy
Caution! Device version not supported	<ul style="list-style-type: none"> • The device description version of the bus operator unit and the software version of the target device do not match • Find compatible versions of memory card and device (VVS) • Exchange the memory card (RMA792) of the bus operator unit or the target device

<i>Error / error message</i>	<i>Cause / remedy</i>
Caution! Device not responding	<ul style="list-style-type: none"> • Communication with target device is not possible • Is the device in operation? • Is the device connected to the Konnex bus? • Has the device address been changed?
Datapoint shows a value that does not make sense (e.g. room temperature 655.3 °C)	The device does not support information describing what is visible; datapoint has no meaning in the current configuration
Setting does not produce any effect	The device does not support information describing what is visible; datapoint has no meaning in the current configuration

3.7 User-defined text

User-defined text from the devices is adopted, which means that the display on the bus operator unit is identical with that on the local operator unit (RMZ790 / RMZ791). The bus operator unit reads the user-defined text from the respective device. The RMZ792 displays the default text until the text from the device is received.

4 Power supply

The bus operator unit can be powered in 3 different ways:

- Via Konnex bus (45 mA)
- Via an external power source (AC 24 V)
- Via the service interface of a Synco™ controller (not recommended)

Notes

- When using the cable supplied with the bus operator unit, plug correctly the RJ45 connector into the appropriate socket of the RMZ792 (audible click)
- Move the KNX / EXT slide switch for selecting the type of power supply to its end position

4.1 Power supply via Konnex bus

- If the bus operator unit is used in a location where AC 24 V power supply is not available (mobile use, installation in some other space), the unit can be powered via the Konnex bus
- Power supply must be such that 45 mA are available for the bus operator unit. This necessitates at least 2 active decentral bus power supplies via Synco™ controllers or 1 central bus power supply
- The slide switch at the rear of the bus operator unit must be set to KNX
- Using the cable supplied with the unit, the RMZ792 is to be connected to a Konnex bus socket (figure a) or a Synco™ controller (figure b)
- The Konnex bus cable is to be connected to terminals CE+ and CE- on the base (figure c; observe polarity)

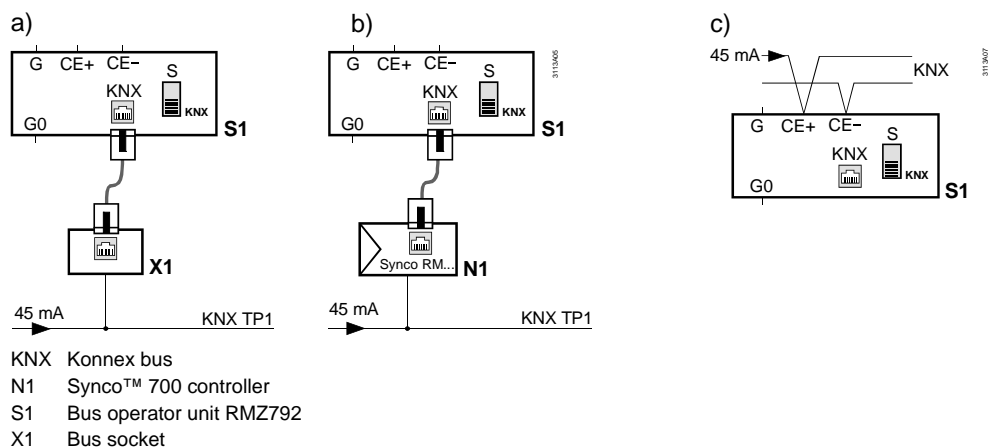

4.2 External power supply

- External AC 24 V power supply is recommended in the case of fixed installations (e.g. in the control panel door). This means that the decentral / central bus power supply does not have to carry the load of the bus operator unit and can be used for powering other bus users
- The slide switch at the rear of the bus operator unit must be set to EXT
- AC 24 V is supplied to the bus operator unit via terminals G and G0

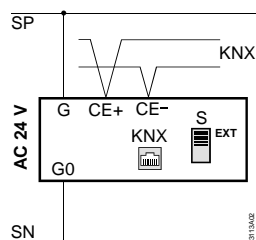

4.3 Power supply via Synco™ controller

- In exceptional cases, the bus operator unit can also be powered via the service interface of a Synco™ controller. Because of the additional power consumption of the bus operator unit, this type of power supply is possible only if the controller is equipped with no more than 3 extension modules
- The slide switch at the rear of the bus operator unit must be set to EXT
- The bus operator unit is to be connected to the service interface of the Synco™ controller using the cable supplied with the unit

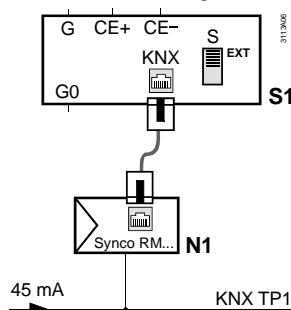

If the bus operator unit is connected while the controller is in operation, the extension modules might deliver fault status messages. The faults may lead to short-time interruptions of plant operation. The fault status messages must be acknowledged and reset.

4.4 Error handling

Possible cases are:

Error	Cause / remedy
Bus operator unit does not start	<ul style="list-style-type: none"> • Wrong polarity CE+ / CE- • Wrong polarity G / G0 • Insufficient power supply via Konnex bus (undersized bus power supply, too low bus voltage) • Wrong slide switch position (KNX / EXT) or switch in an inadmissible intermediate position • RJ45 connector not correctly plugged in (no contact)
Bus operator unit is cyclically restarted	
Konnex bus is locked	
Operating values of the bus users are not correctly displayed or cannot be changed	
Backlit display very faint	
Controller indicates failure of extension modules, parts of the plant fail	<p>The slide switch is in the EXT position and the bus operator unit was connected while the controller was in operation.</p> <p>Remedy:</p> <ol style="list-style-type: none"> 1. Acknowledge the fault status messages and reset them. 2. Connect the bus operator unit to a controller with no extension modules or switch on the controller only after the bus operator unit has been connected.

5 Commissioning



Preparation for use and commissioning of Synco™ 700 devices must be undertaken by qualified staff who have been appropriately trained by SBT HVAC Products or their delegates.

5.1 Entering the commissioning mode

5.1.1 Entry on first startup



When supplying power to the bus operator for the first time, the Language menu appears. Here, the language required for operating the plant can be selected. Then, the Commissioning menu will appear.

The access level is set to "Password level".

The bus operator unit is to be commissioned in accordance with the Installation Instructions G3113; they are enclosed with the RMZ792.

5.1.2 Entry from the main menu

The Commissioning menu is reached after selecting operating line Commissioning (appears only on the password level) and confirmation with the OK knob.

5.2 Leaving the password level

On completion of commissioning, select the user level (access level for the plant operator). To do this, proceed as follows:

1. Select the start page: Press the ESC button repeatedly until the start page reappears.
2. Press the OK knob and the ESC button simultaneously. The Access levels menu appears.
3. Press the OK knob.
4. Select the User level by turning the OK button and confirm by pressing the knob.
5. If required, enter the password needed for the user level.
6. Press the OK knob to confirm the password.

6 “Commissioning” menu

Important!

- Prerequisite for trouble-free operation of the bus operator unit is correct assignment of the device addresses of all bus users including the line couplers
- The device addresses of all bus users and line couplers must accord with their positions in the network topology (area.line.address). Wrong device addresses can lead to unexpected responses and results when commissioning the bus operator unit

6.1 Device address

Like all other bus users, the bus operator unit must have an unambiguous device address. The device address can be set in 3 different ways. Depending on usage, one or the other method is the more suited. The RMZ792 is supplied with the device address set to 0.2.255 (area.line.address).

With device address 255, Synco™ devices do not send any process data. Device addresses 253 and 254 are reserved for special devices.

6.1.1 Automatic address search

- Automatic address search is recommended in situations where the bus operator unit is subsequently fitted to an existing plant without having knowledge of the existing address assignment
- At the request of the operator, the bus operator unit looks for the subnetwork address (SNA, consisting of area and line) in the superposed line coupler. If no subnetwork address is received, the last setting of area and line will be used
- Now, starting at 252, the bus operator unit searches for a free device address within the line. If the address is already used, a new automatic search attempt is made using an address whose value is reduced by 1. The search continues until a free device address is found. The device address is set to 255 if no free device address can be found

6.1.2 Manual assignment of addresses

- Manual assignment of addresses is recommended in situations where the bus operator unit has a firm place in the network and the address from a network plan has already been defined and is known
- Area, Line and Device address are manually predefined by the operator
- If the area or the line is changed, the bus operator unit looks for the subnetwork address (SNA, consisting of area and line) in the superposed line coupler. When the line coupler delivers an SNA, the device adopts the line coupler's SNA and overwrites any deviating manual settings. If no SNA is received, the set value of Area or Line will be adopted
- If the required device address is already used by some other device, the setting value will be reset to the previous value

6.1.3 Address assignment with the ETS

- This programming mode is used when addresses in the Konnex network are assigned with the ETS
- Area, line and device address are predefined in the ETS
- Set the Programming mode on the bus operator unit to On
- Use the ETS to load the respective device address
- After the bus operator unit has received the address, the Programming mode will automatically change to Off

6.1.4 Error handling

Possible cases

<i>Error</i>	<i>Cause / remedy</i>
No communication with other bus users	The device address is 255, which means that communication is not active. Set the device address to a value between 1 and 252 (automatic search or manual predefinition).
	The subnetwork address (area or line) of the line couplers and / or the bus users do not correspond. Check the subnetwork addresses or reassign them.
The subnetwork address (SNA) has not been adopted by the superposed line coupler	There is no superposed line coupler, or the line coupler is configured in a way that it does not send the SNA to the line. Configure the line coupler accordingly or predefine the SNA manually.
Fault status message 6001 >1 identical bus address	There are several bus users with identical device addresses on the network. Correct the device addresses on the respective devices accordingly.

6.2 Activating communication

Communication is activated when:

- The device has a valid device address
- Bus power supply is available
- The device is not on the commissioning menu

6.2.1 Submenu “Communication”

General

A detailed description of communication is given in Basic Documentation P3127 “Communication via Konnex bus”. Basic knowledge of device addresses and network topologies is a prerequisite here.

Operating lines

 Main menu > Commissioning > Communication

<i>Operating line</i>	<i>Range</i>	<i>Factory setting</i>
Area	0...15	0
Line	0...15	2
Device address	1...255	255
Search address	--- / Address found	---
Programming mode	Off / On	Off

Setting values Area, Line and Device address are used to manually create individual device addresses.

Automatic address search is triggered via operating line Search address. A successful address search is acknowledged with status Address found. Status Address failed indicates that the address search has been unsuccessful.

For assigning addresses via the ETS, the programming mode must be set to On. After successful address assignment, the ETS will automatically switch the value back to Off.

Notes

- If a line coupler superposed in the network topology delivers SNA information other than the values set for the area and the line, the line coupler's values will be adopted
- If 2 devices have identical device addresses, an error message will be delivered

6.3 Device list

Definition

The device list is the list containing the bus users that can be operated. The system switches from the device list of the bus operator unit to the menu tree of the bus user. Bus users that do not appear on the device list cannot be operated via the bus operator unit.

Presentation

Bus users are presented on the device list as follows:

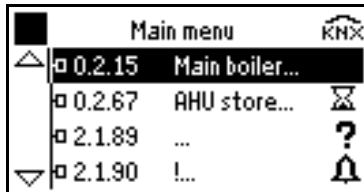

Information	Description
	Symbol for bus user
A.L.A	Konnex device address (optional): B : Area [0...15] L : Line [0...15] A : Address [1...255] Also refer to subsection 6.3.7 "Submenu "Display list""
Name	Device name: Main boiler : Text, max. 20 characters ("Main boiler" is an example!) ... : Device without name !... : Name of device cannot be read Also refer to subsection 6.3.3 "Submenu "Name devices""
State	Device state: : Device in order, no fault pending : Device indicating a fault : State read by the device : State cannot be read, potential failure Also refer to subsection 10.1.1 "Device list on the "Main menu""

Functions

A number of functions make it possible to generate a device list matched to the individual requirements of the user:

- Automatic search for Synco™ devices within a line or area
- Adding Synco™ devices later:
 - Individual devices
 - All devices within an line
 - All devices within an area
- Removing individual devices from the device list
- Naming and renaming device names on the device list
- Selecting presentation of the devices on the device list
- Changing the order of the devices on the device list
- Deleting the entire device list

In connection with the device list operations, the following status messages are displayed, depending on the menu:

Status messages	Description
---	Command has not yet been executed
	Command is being executed
Searched for	Device list has been successfully created
Added	Devices have been successfully added to the list
Address invalid	Device searched for does not exist or does not reply

<i>Status messages</i>	<i>Description</i>
Sorted	Device list has been successfully sorted
Deleted	Device list has been successfully deleted
Sorted	Device search not possible with the current settings of area and line

6.3.1 Submenu “Create list”

Use

- When the bus operator unit is connected to plant for the first time
- When the bus operator unit is connected to plant as a service unit

Operating lines

 Main menu > Commissioning > Device list > Create list

<i>Operating line</i>	<i>Range</i>	<i>Factory setting</i>
Area	0...15	0
Line	* / 0...15	2
Start search	--- / Searched for	---
Number of devices current	0...150	0

A search is made in the network for operable Synco™ devices in accordance with the parameters set. An existing device list will first be deleted. The search for devices is only possible within the selected area. Settings Area and Line confine the search for bus users to the required part of the network. This also reduces the time required for the search to a reasonable level.

When using setting “*” for the line, the search covers all lines of the required area. In that case, the search lasts about 15 minutes and cannot be aborted.

The device search is started via operating line Start search.

The number of devices found is displayed by the value of Number of devices current.

Caution

When creating the device list, all existing devices, device names and favorite pages will be deleted!

Notes

- The device list can comprise a maximum of 150 devices. If a network contains more than 150 bus users, the search will be stopped after 150 devices. On the List information menu, a List error is shown as List complete
- In the case of plant with several bus operator units, only one of them can make a search run at a time
- A device search across all lines (Line = *) is only possible in the bus operator unit's own area
- Settings Area and Line must not be changed during the device search run.
- If a power failure occurs during a search run, or if the bus operator unit is removed during a search run, the device list will be declared List invalid
- Commands are ignored as long as a device search run is in progress
- When creating the device list, the local names of the devices will be adopted by the list. If, subsequently, the name is changed locally on the controller, the device list will not automatically be updated

6.3.2 Submenu “Sort list”

Use

- Sorting the device list in ascending device address order
- Sorting the device list in ascending device name order
- Sorting manually with the aim to have frequently operated devices at the beginning of the list

Operating lines

 Main menu > Commissioning > Device list > Sort list

<i>Operating line</i>	<i>Range</i>	<i>Factory setting</i>
Sort automatically by	Device addresses / Device names	---
Sort manually		

The device list can be sorted either manually or automatically according to predefined criteria. The sorting process is started via operating line Sort automatically and can be performed by Device address or Device name.

The device list can be manually sorted on the following submenu.

Operating lines

 Main menu > Commissioning > Device list > Sort list > Sort manually

<i>Operating line</i>	<i>Range</i>	<i>Factory setting</i>
Device address name 1	1...150	
...		
Device address name n	1...150	

After selection of a device, its current position on the device list is displayed. By adjusting the value, the respective device can be shifted to the required position. The position of each device on the device list can be freely selected (1 = beginning of list, 150 = end of list). The positions of the other devices will then automatically be changed; the list does not permit any gaps. If the required position lies behind the current end of the list, the device will be placed in the last position.

6.3.3 Submenu “Name devices”

Use

Assignment of easy-to-understand and self-explanatory names to the devices.

Operating lines

 Main menu > Commissioning > Device list > Name devices

<i>Operating line</i>	<i>Range</i>	<i>Factory setting</i>
Device address name 1	Max. 20 characters	
...		
Device address name n	Max. 20 characters	

The devices on the device list can be assigned a freely selectable name. When creating the device list and when adding devices, the local device name – if available – will be adopted by the device list. The name of the selected device can be overwritten. The name change only affects the device list on the bus operator unit; the local name of the device will be maintained. A device name can comprise a maximum of 20 characters. A device name also appears on the bus operator unit:

- As the title of the main menu of a bus user
- For orientation purposes if, during navigation in a device's menu tree, the INFO button is pressed
- On the menu and info pages for fault indication

6.3.4 Submenu “Add devices”

Use

- Adding an individual device to the device list
- Adding devices from some other area to the device list
- Adding devices from some other line to the device list
- Updating the device list

Operating lines

 Main menu > Commissioning > Device list > Add devices

<i>Operating line</i>	<i>Range</i>	<i>Factory setting</i>
Area	0...15	0
Line	* / 0...15	2
Device address	* / 1...255	*
Start add on	--- / Added	---
Number of devices current	0...150	

A search for operable Synco™ devices is made in the network according to the parameters set. The devices found are added to the existing device list. Devices already contained on the device list will not be added again. Settings Area, Line and Device address confine the search for operable devices to the required part of the network, or even to an individual device. This also reduces the search time to a reasonable level.

- When using setting * for the line, the search for devices runs through all the lines of the required area
- When using setting * for the device address, the search is started for all devices within the line

The function is started via operating line Start add on.

The number of devices found is displayed by the value of Number of devices current.

Note

Same notes as in section 6.3.1 “Submenu “Create list”” apply.

6.3.5 Submenu “Delete devices”

Use

- Reduction of the device list to the devices most important to the user
- Exclusion of individual devices from operation

Operating lines

 Main menu > Commissioning > Device list > Delete devices

<i>Operating line</i>	<i>Range</i>	<i>Factory setting</i>
Device address name 1		
...		
Device address name n		

After a security check is made, the selected device will be removed from the device list. The gap on the device list will be closed. Any datapoints of the deleted device will be removed from the favorite pages.

6.3.6 Submenu “Delete list”

Use

Deleting the entire device list.

Operating line

 Main menu > Commissioning > Device list > Delete list

<i>Operating line</i>	<i>Range</i>	<i>Factory setting</i>
Delete list	--- / Deleted	---

After a security check is made, the entire device list inclusive of device names will be deleted. In addition, all favorite pages will be deleted.

6.3.7 Submenu “Display list”

Use

- Changing the display format of the device list
- Showing the device address on the device list or hiding it

Operating lines

 Main menu > Commissioning > Device list > Display list

<i>Operating line</i>	<i>Range</i>	<i>Factory setting</i>
Type of display	Address and name / Name only	Address and name

Depending on the selection made, the devices appear on the device list with their addresses and names, or only with their names.

6.3.8 Submenu “List information”

Use

Displaying detailed information about the current state of the device list.

Operating lines

 Main menu > Commissioning > Device list > List information

<i>Operating line</i>	<i>Range</i>	<i>Factory setting</i>
State of list	See below	
List error	See below	
Number of devices current	0...150	

State of list and list errors have the following meaning:

<i>State of list</i>	<i>Description</i>
Address invalid	Device search has been aborted; device list is invalid and must be recreated
Deleted	Device list is empty
Acquired	Device list has been created or devices have been added

<i>List error</i>	<i>Description</i>
---	No error; device list is ok
Address twice	Device list contains several devices with identical device addresses. Address conflict must be eliminated
List complete	List is full (150 entries)

The current number of devices on the device list is displayed by the value of Number of devices current.

6.4 Favorites

Definition

Favorite pages enable the user to quickly access important and frequently used plant values. A total of 20 pages is available, each with a maximum of 10 datapoints. The user can freely assign any datapoints of devices on the device list. Favorite pages and operating lines not used are not displayed in the view of favorites. All favorite pages show the  symbol in the corner at top right.

All datapoints of the favorite pages can be accessed from the user level, also in the case where the datapoint in the bus user’s menu tree only appears on the service level.

Functions

A number of functions make it possible to match the favorite pages to individual operator needs:

- Adding favorite pages and datapoints
- Naming the favorite pages (titles)
- Renaming the names of the datapoints
- Sorting the favorite pages
- Deleting datapoints and entire favorite pages

Notes

- To improve readability, it is recommended to give the favorite pages self-explanatory names
- If individual devices are removed from the device list, the associated datapoints on the favorite pages will also be removed
- When deleting the entire device list, all favorite pages will be deleted also



6.4.1 Submenu “Add datapoints”

Use

- Creating favorite pages
- Complementing favorite pages
- Overwriting existing datapoints

Operating lines

 Main menu > Commissioning > Favorite pages > Add datapoints

<i>Operating line</i>	<i>Range</i>	<i>Factory setting</i>
Favorites 1		Favorites 1
...		
Favorites 20		

 Main menu > Commissioning > Favorite pages > Add datapoints > Favorites 1 to Favorites 20

<i>Operating line</i>	<i>Range</i>	<i>Factory setting</i>
Datapoint name 1		...
...		
Datapoint name 10		...

The favorite pages are presented with the title defined by the user. The factory setting of the titles is Favorites 1...Favorites 20. Datapoints are presented with their names (copy from the device menu tree). They can subsequently be renamed. Operating lines that are not used appear as

Any datapoints from the menu trees of the devices on the device list can be assigned to the favorite pages. The position – favorite page and line – can be freely selected. It is also possible to overwrite existing datapoints by other datapoints. Subsequent sorting of datapoints within the page is not possible.

Datapoints having a complex graphic display cannot be included in the favorites (time switch, calendar, trend display, faults, etc.). Also, datapoints from the menus Commissioning, Favorites, Favorite pages and Device list of the bus operator unit itself cannot be included in the favorites either.

Operating mode Add datapoints is indicated by the  symbol in the corner at top right.

A datapoint is added according to the following procedure:

- Select the respective favorite page (1...20)
- Select the respective operating line (1...10)
- Select the device from the device list
- Navigate to the respective datapoint in the target device
- Select the datapoint with the OK knob
- Confirm adding with the OK knob and canceling with the ESC button
- Return automatically to the selected favorite page (OK knob), or return to the selected datapoint (ESC button)

Operating mode Add datapoints is quit under the following conditions ( symbol extinguishes):

- A datapoint has been successfully assigned to a favorite page
- Navigation to the start page (press ESC buttons several times, or long press)
- Navigation to the Commissioning menu
- Navigation to the Favorites menu
- Navigation to the Favorite pages menu
- Navigation to the Device list menu
- No action for 30 minutes

Note

All datapoints of the favorite pages can be operated from the user level, irrespective of where they appear, in the bus user's menu tree, on the user level, or on the service level.

6.4.2 Submenu "Name datapoints"

Use

Renaming the datapoints on a favorite page.

Operating lines

 Main menu > Commissioning > Favorite pages > Name datapoints

<i>Operating line</i>	<i>Range</i>	<i>Factory setting</i>
Datapoint name 1	Max. 20 characters	
...		
Datapoint name 10	Max. 20 characters	

When assigning datapoints from the menu tree of a device, the name of the data source will be copied. The names of the datapoints on the favorite pages can be changed, e.g. in the case of several datapoints within the same favorite page that carry the same name. The bus operator unit will not automatically adopt a subsequent change of name of the data source.

6.4.3 Submenu "Name favorites"

Use

Naming the favorite page by using a self-explanatory title.

Operating lines

 Main menu > Commissioning > Favorite pages > Name favorites

<i>Operating line</i>	<i>Range</i>	<i>Factory setting</i>
Favorite title 1	Max. 20 characters	Favorites 1
...		
Favorite title 20	Max. 20 characters	Favorites 20

To simplify finding the correct favorite page, it is recommended to replace the default title of a page by a self-explanatory name. The pages displayed must contain at least 1 datapoint.

6.4.4 Submenu "Sort favorites"

Use

- Changing the order of favorite pages
- Putting frequently used favorite pages to the beginning of the list

Operating lines

 Main menu > Commissioning > Favorite pages > Sort favorites

<i>Operating line</i>	<i>Range</i>	<i>Factory setting</i>
Favorite title 1	1...20	
...		
Favorite title 20	1...20	

After a favorite page has been selected, its current position within the list of the presented favorite pages will be shown. By changing the value, the selected page can be

shifted to the required position. The position of each page can be freely selected (1 = first page presented, 20 = last page presented). If the required position lies beyond the current end of the list, the page will be placed in the last position.

Notes

- Prior to sorting the favorite pages, the default titles are to be replaced by self-explanatory titles (refer to section 6.4.3 “Submenu “Name favorites””)
- If favorite pages are sorted based on the default titles, the datapoints will be correctly resorted. But the title changes depending on the position and assignment to the favorite pages so that misunderstandings can arise

6.4.5 Submenu “Delete datapoints”

Use

Deleting individual datapoints on a favorite page.

Operating lines

 Main menu > Commissioning > Favorite pages > Delete datapoints

<i>Operating line</i>	<i>Range</i>	<i>Factory setting</i>
Favorite title 1		Favorites 1
...		
Favorite title 20		Favorites 20

 Main menu > Commissioning > Favorite pages > Delete datapoints > Favorites 1 to Favorites 20

<i>Operating line</i>	<i>Range</i>	<i>Factory setting</i>
Datapoint name 1		
...		
Datapoint name 10		

First, select the relevant favorite page and then delete the datapoint. Confirm the deletion by pressing the OK knob.

Note

After deletion of the last datapoint, the empty favorite page is retained. The entire page can be deleted via submenu Delete favorites.

6.4.6 Submenu “Delete favorites”

Use

Deleting individual favorite pages.

Operating lines

 Main menu > Commissioning > Favorite pages > Delete favorites

<i>Operating line</i>	<i>Range</i>	<i>Factory setting</i>
Favorite title 1		Favorites 1
...		
Favorite title 20		Favorites 20

After a security check is made, all favorite pages with their titles and all their datapoints will be deleted. The favorite page is now empty, and menu Add datapoints can be used to assign new datapoints.

6.4.7 Submenu “Delete all favorites”

Use

Deleting all favorite pages.

Operating lines

 Main menu > Commissioning > Favorite pages > Delete all favorites

<i>Operating line</i>	<i>Range</i>	<i>Factory setting</i>
Delete all favorites	--- / Deleted	---

After a security check is made, all favorite pages with their titles and all their datapoints will be deleted.

7 Data backup

Use

- Making a backup copy of the settings
- Restoring the safe settings after unsuccessful changes
- Securing or restoring the settings when changing the memory card

Function

When commissioning is completed, the settings of the bus operator unit can be saved. Later – e.g. after unauthorized changes or after inadvertent changes or deletions of settings – these settings can simply be retrieved.

Data backup or restoration of data can take place at 2 different locations:

- Locally, that is, on the memory card (RMA792) of the bus operator unit
- On the second device, that is, on the memory card of a second bus operator unit connected to the bus

Storage on a second device is especially practical when, for compatibility reasons, the memory card of the bus operator unit must be replaced.

Data backup saves the following settings:

- Device list including the device name, order and display format
- Favorite pages with all datapoints
- Names and order of favorite pages
- Setting the display of fault status messages on the bus (refer to section 8.5 “Display of bus fault status messages”)

All other settings (device address, language, etc.) will **not** be saved.

After successfully restoring all settings, the bus operator unit will be restarted.

The following status messages will be displayed, depending on the action performed:

Status messages	Description
---	Command has not yet been executed
Restored	The settings have been successfully restored
Saved	The settings have been successfully saved
Failed	An error occurred during data backup or data restoration

Note

To avoid compatibility problems between the settings on the RMA792 memory card and the RMZ792 bus operator unit, following rule must be observed:

The software version of the bus operator unit must be identical to or higher than the software version with which the settings were saved.

7.1 Local data backup

Operating lines

 Main menu > Data backup > Local

Operating line	Range	Factory setting
Restore	--- / Restored / Failed	---
Save	--- / Saved / Failed	---
Progress	---- / 0...100 %	----
Storage date	01.01...31.12	Date of last storage
Storage year	2000...2080	Year of last storage

Operating line Save or Restore triggers the relevant copy process for the setting values. The progress of the copy process is continuously displayed [0...100 %] and lasts about 15 seconds.

Note

Storage date and Storage year only show sensible values if the bus operator unit received a valid system time at the time of data backup.

7.2 Data backup on a second unit

General

Before the settings can be saved on a second bus operator unit, that unit must be installed on the bus and be fully functioning. The second unit can also be located in some other area or some other line of the network. The target address of the second bus operator unit is to be set on submenu Address.

Operating lines

 Main menu > Data backup > Second device > Address

<i>Operating line</i>	<i>Range</i>	<i>Factory setting</i>
Area	0...15	0
Line	0...15	2
Device address	1...255	255

Operating lines

 Main menu > Data backup > Second device

<i>Operating line</i>	<i>Range</i>	<i>Factory setting</i>
Restore	--- / Restored / Failed	---
Save	--- / Saved / Failed	---
Progress	---- / 0...100 %	----

Operating line Save or Restore triggers the relevant transfer of the setting values. The progress of the copy process is continuously displayed [0...100 %] and can last up to 3 minutes.

Notes

- When transferring data to the second bus operator unit, local data backup of the second unit will be overwritten, which means that locally saved settings of the second unit will be lost. The date of local backup will be overwritten by the date on which the data are transferred
- To avoid loss of data, the bus operator units involved must not be switched off or removed during data transfer
- The bus operator unit cannot be used during the time data are transferred. To avoid data corruption, simultaneous data backup or data restoration must not be performed on the second unit

7.3 Error handling

Possible cases

<i>Error</i>	<i>Cause / remedy</i>
Save Failed Progress ---- % Setting not saved	<ul style="list-style-type: none"> • Invalid address of the second unit • Communication breakdown to the second unit Remedy: <ul style="list-style-type: none"> • Check bus connection and address of the second unit • Make a new data backup
Save Failed Progress 1...99 % Settings incompletely saved	<ul style="list-style-type: none"> • Communication breakdown or power failure during data backup on the second unit Remedy: <ul style="list-style-type: none"> • Check bus connection and power supply • Make a new data backup
Restore Failed Setting not restored No new start of bus operator unit	<ul style="list-style-type: none"> • Invalid address of the second unit • Communication breakdown to the second unit Remedy: <ul style="list-style-type: none"> • Check bus connection and address of the second unit • Restore data again
Restore Failed Settings incompletely restored, device list has been deleted New start of bus operator unit	<ul style="list-style-type: none"> • Corrupted backup data • Incompatible software version of backup data • Communication breakdown or power failure during data restoration on the second unit Remedy: <ul style="list-style-type: none"> • Check bus connection and power supply • Use consistent and compatible backup data • Restore data again

8 General settings

8.1 Time of day and date

Yearly clock

The bus operator unit does not have its own yearly clock. If some other bus user (clock time master) sends the time of day, the weekday and the date, that information will be adopted and displayed by the bus operator unit. The correct operation of time switch, calendars, etc., necessitates a clock time master.

8.1.1 Format

Selectable time formats

The following time formats are available:

24 h

- The **date** is displayed as dd.mm.yyyy (day.month.year).
Example: 31.05.2006
- The **time of day** appears as hh:mm (hours:minutes)
Example: 15:56

am/pm

- The **date** is displayed as mm/dd/yy (month/day/year).
Example: 05/31/06
- The **time of day** is displayed as hh:mm am/pm (hours:minutes am/pm).
Example: 03:56 PM

Setting

■ Main menu > Settings > Device

<i>Operating line</i>	<i>Range</i>	<i>Factory setting</i>
Time format	24 hours 12 hours (am/pm)	24 h

Note

Time of day and date are always displayed in the format of the bus operator unit, independent of the settings of the various bus users.

8.1.2 Setting

The bus operator unit can be used to readjust the system time of the clock time master and thus the local display of time of day and date also.

■ Main menu > Time of day/date

<i>Operating line</i>	<i>Range</i>	<i>Factory setting</i>
Time of day	00:00...23:59 / 12:00am...11:59pm	
Date	01.01. ...31.12	
Year	2000...2080	

8.1.3 Error handling

Possible cases

<i>Error</i>	<i>Cause / remedy</i>
Time of day, weekday and date are not shown on the start menu	<ul style="list-style-type: none"> • In the system, bus users do not send the system time (there is no clock time master) • The bus operator unit has not received any system time telegram since it was switched on • Any of the line couplers does not forward the telegram
The displays for the time switch, calendar, etc., show the date 01.01.2000	

8.2 Selecting the language

Behavior when switching on for the first time

The bus operator unit has several languages loaded. When switching the unit on for the first time, the Language menu appears (in English). The language can also be changed later on during operation.

Choice of languages

The following languages are available:

English English
 German German
 Francais French
 Italiano Italian
 Nederlands Dutch
 Polski Polish
 Cesky Czech
 Magyar Hungarian
 Espanol Spanish
 Dansk Danish
 Norsk Norwegian
 Svenska Swedish
 Suomi Finnish
 Ellinika Greek
 Russkij Russian
 (Limba) Romana ... Romanian
 Slovensky Slovakian
 Slovenski Slovenian
 Srpski Serbian
 Hrvatski Croatian

Setting

 Main menu > Settings > Device

<i>Operating line</i>	<i>Range</i>	<i>Factory setting</i>
Language	English, German, ...	English

Notes

- With the exception of user-defined text, all operating text is always displayed in the language selected on the bus operator unit, independent of the settings made by the different bus users
Exception: User-defined text and fault text from other bus users is displayed unchanged
- Heterogeneous language selections made on the bus operator unit and by the bus users can lead to the display of illegible, erroneous text. The language selection for the plant concerned should be the same

- With the bus operator unit, it is also possible to change the language of a bus user (Synco™ 700 controllers type RMx7...). The language is selected via the device list on the respective menu of the bus user. If the selected language does not exist with the bus user, a change to English is made.

8.3 Selecting the unit of temperature

Setting

The units of temperature that can be selected for the bus operator unit are °C (or K) and °F:

 Main menu > Settings > Device

<i>Operating line</i>	<i>Range</i>	<i>Factory setting</i>
Unit	°C / °F	°C

Note

Temperatures are always displayed with the unit selected on the bus operator unit, independent of the settings made by the various bus users.

8.4 Contrast of display on the operator unit

Setting

The contrast of the display can be matched to the environmental conditions.

 Main menu > Settings > Device

<i>Operating line</i>	<i>Range</i>	<i>Factory setting</i>
Contrast	0...100 %	50 %

8.5 Display of bus fault status messages

Setting

The following parameter defines the fault status messages displayed on the menu or info page Fault status message bus.

 Main menu > Settings > Faults

<i>Operating line</i>	<i>Range</i>	<i>Factory setting</i>
Fault status message bus	Device list only / All devices	Device list only

- Device list only:
Fault status messages are only displayed by devices contained on the device list.
- All devices:
Fault status messages are displayed by all Synco™ devices on the Konnex network. Faults of devices not contained on the device list can neither be acknowledged nor reset; also, they are not indicated by the fault LED.

8.6 Text entries

Entries

Both the device name of the bus operator unit and the business card can be freely defined. The device name is shown on the start menu, the 4 text lines of the business card are displayed in the form of an info picture.

 Main menu > Settings > Texts

<i>Operating line</i>	<i>Range</i>	<i>Factory setting</i>
Device name	Max. 20 characters	
Business card line 1	Max. 20 characters	
Business card line 2	Max. 20 characters	
Business card line 3	Max. 20 characters	
Business card line 4	Max. 20 characters	

8.7 Password

Each of the 3 operating levels (User level, Service level and Expert level) can be protected against unauthorized access through the use of passwords. The expert level is the password level used by the bus operator unit. For the bus operator unit, the terms "Password level" and "Expert level" have the **same** meaning.

Settings

 Main menu > Settings > Passwords

<i>Operating line</i>	Range	Factory setting
User level	0...9999	0, that is, no password
Service level	0...9999	0, that is, no password
Expert level	1...9999	7

The passwords can only be changed on the password level. Setting value 0 means "no password", indicating that no password is required when accessing the respective operating level.

Important!

The password required for the password level should be kept in a safe location! If the password is lost, it will not be possible to retrieve the factory settings!

8.8 Device list

Certain menus for editing the device list are available both on the password level and the less protected service level. Functionality on the service level is restricted to sorting, naming and renaming devices, and to selecting the way of presentation.

 Main menu > Device list > Sort list

 Main menu > Device list > Name devices

 Main menu > Device list > Display list

 Main menu > Device list > List information

The individual functions are described in chapter 5 "Commissioning".

8.9 Favorite pages

Certain menus for editing the favorite pages are available both on the password level and the less protected service level. Functionality on the service level is restricted to sorting, naming or renaming favorite pages and datapoints.

 Main menu > Favorite pages > Name datapoints

 Main menu > Favorite pages > Name favorites

 Main menu > Favorite pages > Sort favorites

The individual functions are described in chapter 5 "Commissioning".

9 Device information

Menu Device information provides information about the current version of the bus operator unit.

Displays

■ Main menu > Device > Device information

<i>Operating line</i>	<i>Remarks</i>
Software version	Display of type reference of bus operator unit (RMZ792)
Software version	Display of software version of bus operator unit
Hardware version	Display of hardware version of bus operator unit
Memory card type	Display of type of memory card (RMA792)
Memory card version	Display of software version of memory card

If the bus operator unit is not able to address certain devices (error message Device version not supported), it is recommended to compare the memory card version of the bus operator unit and the software version of the respective device with the current Valid Version Set (VVS). Exchange of the memory card by a new version is described in section 11.2 "Exchanging the memory card".

10 Faults

As a matter of principle, the bus operator unit only handles faults of devices contained on the device list.

When starting up, it can take up to 3 minutes for the device fault information to be updated, depending on the size of the device list.

When using network topologies with line couplers, it must be made certain that the line couplers forward correctly the devices' fault information (LTE broadcast) to the bus operator unit (filter tables must be appropriately configured).

10.1 Display of faults

Fault status messages delivered by the bus users are displayed by the bus operator unit on a number of menus. Faults can be acknowledged by the bus operator unit and – if permitted by the respective device – can also be reset.

The fault LED in the fault button flashes or is lit when faults are pending:

<i>State of LED</i>	<i>Description</i>
LED dark	No faults pending
LED flashes	Unacknowledged faults
LED lit	Fault still pending or not yet reset

Note

The state of the LED (flashing / steady on) can differ between the bus operator unit and a bus user if a fault relay has been configured on the operator unit.

Additional information about faults is given at different locations:

<i>Location</i>	<i>Description</i>
Info page Fault status message bus	Display of the most severe error (also refer to subsection 10.1.3 "Info page and menu "Fault status message bus"")
Device list on the Main menu	Fault symbol  indicating faulty devices
Menu Faults current	List of a maximum of 20 faults sorted by priority, state of acknowledgement and date / time of day
Menu Fault status message bus	Display of the most severe fault (also refer to subsection 10.1.3 "Info page and menu "Fault status message bus"")
Fault menus of the respective devices	Fault information from the local fault menus in the menu tree of the respective controllers or devices (e.g. fault history)

The type of acknowledgement of a fault status message is determined by the fault source (e.g. Synco™ 700 controller). Depending on the type of acknowledgement demanded, a fault status message is acknowledged in one of the 3 following ways:

<i>Type of acknowledgement</i>	<i>Description</i>
None	Fault must neither be acknowledged nor reset. The fault status message disappears automatically when the cause of the fault has been removed
Acknowledge	The fault is displayed until it is acknowledged (even if in the meantime, the cause of the fault has been removed)
Acknowledge and reset	The fault must first be acknowledged and, after removal of the cause of fault, reset

10.1.1 Device list on the “Main menu”



The fault state of the devices is shown on the main menu by a symbol on the right hand side. The symbols have the following meaning:

<i>Fault symbol</i>	<i>Description</i>
	Device in order, no fault pending
	Device faulty
	Device reads information about the fault
	Possibility of device failure, information about fault cannot be read or is not periodically forwarded

After starting up the bus operator unit, it can take up to 3 minutes for the fault state of all devices to be updated, depending on the size of the device list.

10.1.2 Menu “Faults current”

■ Main menu > Faults > Faults current



This menu combines a maximum of 20 pending faults. The faults are sorted by fault priority.

Note

The order of fault status messages on the fault lists of Synco™ controllers and the bus operator unit can differ, depending on priority information.

10.1.3 Info page and menu “Fault status message bus”

i Fault status message bus and

■ Main menu > Faults > Fault status message bus



The above example shows a “most severe fault” of all devices on the device list or of all Synco™ devices in the entire Konnex network. The display depends on the setting described in section 8.5 “Display of bus fault status messages”.

10.2 Faults of non-listed bus users

Fault status messages from bus users not contained on the device list are handled differently (refer to section 8.5 “Display of bus fault status messages”, depending on the setting of parameter Fault status message bus:

- Setting Device list only:
Fault status messages from non-listed bus users will be ignored.
- Setting All devices:
If, at present, the fault status message from a non-listed bus user is the most severe pending, it will **only** appear on the menu and on info page Fault status message bus. The fault LED will not be lit. Acknowledgement and reset with the fault button is not possible and must be made locally on the respective device.

10.3 Acknowledgement of faults

When pressing the flashing fault button, all faults to be acknowledged will be acknowledged. Only faults of devices from the device list will be acknowledged. Acknowledgement can take place from any of the menus.

Notes

- When a device list is full, acknowledgement of faults can take up to 1 minute
- Faults of Synco™ devices not contained on the device list **cannot** be acknowledged

10.4 Resetting faults

Only faults of devices from the device list can be reset. In contrast to fault acknowledgements, faults must be reset on an individual basis. A reset is made by pressing the illuminated fault button.

To ensure that the fault and the reset command can be unambiguously assigned, resetting of the current or the displayed fault can only take place on the following menus:

- On info page Fault status message bus of the bus operator unit
- On menu Fault status message bus of the bus operator unit
- On menu Faults current (faults 1...20) of the bus operator unit
- On the Main menu of the bus operator unit when the faulty device has been selected
- Locally on the faulty device (by pressing the fault button)

Notes

- Faults of Synco™ controllers can be reset via the bus operator unit only if setting Remote reset of fault is activated.
Example of universal controller type RMU710:
Main menu > Commissioning > Communication > Basic settings
- Faults of Synco™ devices not contained on the device list cannot be reset.

10.5 Deleting faults

The fault history of a controller cannot be deleted from the bus operator unit; this is only possible locally on the actual bus user.

11 Memory card

11.1 Content of memory card

The exchangeable RMA792 memory card contains text catalogs in different languages and the device descriptions of the bus users. The version of the bus user and that of the respective device description must accord. For new versions or new types of Syn-co™ devices, the memory card must be updated, that is, exchanged. If incompatible, the bus operator unit will display an appropriate error message.

11.2 Exchanging the memory card



To exchange the memory card, the bottom of the housing must be opened. The memory card must be exchanged when power is disconnected. The memory card can be removed and replaced with no need for using a tool. When the unit is open, protective ESD measures must be observed; the electronic components on the printed circuit board must not be touched.



Removing the memory card



Fitting the memory card

12 Support in the event of errors and faults

12.1 Error code list

The list only covers the errors that can result from the connection and operation of the bus operator unit. For notes relating to other error codes, refer to the descriptions of the respective devices.

<i>Number</i>	<i>Cause of error / fault</i>	<i>Effect</i>
6001	>1 identical device address	Urgent message; must be acknowledged

12.2 Rectification of errors

<i>Error / error message</i>	<i>Cause / remedy</i>
When creating the device list (Create list, Add devices), devices outside the search range will also be included on the list	The device address (area.line.address) of the bus operator unit and / or of other bus users does not match the current bus topology. Check the device addresses and, if required, make corrections
Caution! Device version not supported	Version of bus operator unit's device description and software version of the target device do not match. <ul style="list-style-type: none"> Find compatible versions of memory card and device (VVS) Exchange memory card (RMA792) of bus operator unit or target device
Caution! Device not responding	Communication with the target device is not possible. <ul style="list-style-type: none"> Is the device in operation? Is the device connected to the Konnex bus? Has the device address been changed?
Datapoint shows a value that does not make sense (e.g. room temperature 655.3 °C)	Device does not support information describing what is visible; datapoint has no meaning in the current configuration
Datapoint setting shows no effect	Device does not support information describing what is visible; datapoint has no effect in the current configuration
Device switches itself off from time to time	<ul style="list-style-type: none"> Bus operator unit is powered via Konnex. Bus power supply is undersized and is not able to power the bus operator unit. Use more powerful supply, or Use external AC 24 V power supply for the bus operator unit
Extremely faint backlit display	
Operating values of bus users are not correctly displayed or cannot be changed	

<i>Error / error message</i>	<i>Cause / remedy</i>
During commissioning, the wrong language was selected. How do I find "my" language?	<ol style="list-style-type: none"> 1. Press simultaneously the ESC button and the OK knob. 2. Select the password level, enter 112 as the password (same no. as international emergency call) and confirm by pressing the OK knob. The language changes to English. 3. Go to menu Settings > Device > Language to change to the required language.
Start menu does not show time of day, week-day and date	<ul style="list-style-type: none"> • No bus user in the system uses the system time (no clock time master) • Since it was switched on, the bus operator unit has received no system time telegram • Any of the line couplers does not forward (filter) the telegram
The views of time switch, calendar, etc., show the date 01.01.2000	
Fault information from room controllers (e.g. RXB2...) is not available (display "?" on the device list)	The controller only communicates in S-mode. Set communication of the room controller with the ETS or ACS to LTE mode and S-mode
Controller does not accept the Room number or the Device name of the individual room controller (e.g. RXB2...)	The Room number may comprise no more than 5 characters, the Device name no more than 10 characters. Text entries must be appropriately shortened
Bus operator unit cannot reset the fault status message from a controller	Remote reset of faults is not permitted. Make appropriate setting on the controller (refer to section 10.4 "Resetting faults").

13 Electrical connections

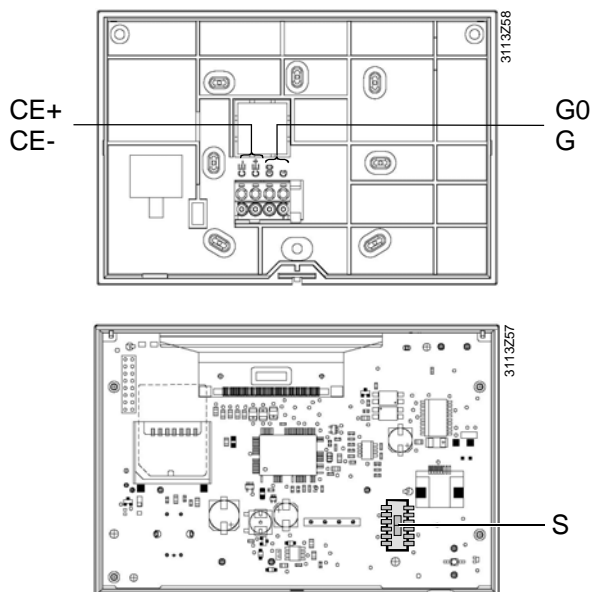

- G, G0 Connection terminals for AC 24 V operating voltage
- CE+ Connection terminals for Konnex bus data line (positive)
- CE- Connection terminals for Konnex bus data line (negative)
- KNX Socket for Konnex bus (RJ45)
- S Slide switch for selecting the type of power supply
 - KNX: Power supply via Konnex bus (45 mA)
 - EXT: External power supply via G, G0 (AC 24 V)

Note

Ensure that the slide switch is in its correct position (KNX or EXT), depending on the type of power supply (refer to chapter 4 "Power supply").

14 Appendix

14.1 Abbreviations used in this document

The following list contains the abbreviations most frequently used (in alphabetical order):

<i>Abbreviation</i>	<i>Meaning</i>
AC	Alternating Current
ACS	ACS7... commissioning and operating software
EIB	European Installation Bus (will be replaced by Konnex)
ETS	Engineering Tool Software (Konnex / EIB)
KNX	Konnex bus connection (for operation and process information)
LTE mode	New communication standard used by Synco and RXB
S-mode	Like EIB up to now
LCD	Liquid Crystal Display
LED	Light Emitting Diode
MMI	Man Machine Interface
SNA	Konnex Subnetwork Address (area and line)
VVS	Synco Valid Version Set, list of compatible versions

14.2 Editable text

The list with editable text shall serve as an aid for engineering and commissioning. Maximum length of the text is 20 characters.

 Main menu > Settings > Texts

<i>Name of datapoint</i>	<i>User-defined text</i>
Device name	
Business card line 1	
Business card line 2	
Business card line 3	
Business card line 4	

 Main menu > Commissioning > Device list > Name devices

<i>Name of datapoint</i>	<i>User-defined text</i>
Device name 1	
Device name 2	
Device name 3	
Device name 4	
Device name 5	
Device name 6	
Device name 7	
Device name 8	
Device name 9	
Device name 10	
...	
Device name 150	

 Main menu > Commissioning > Favorite pages > Name favorites

<i>Name of datapoint</i>	<i>User-defined text</i>
Favorite title 1	
Favorite title 2	
Favorite title 3	
Favorite title 4	
Favorite title 5	
Favorite title 6	
Favorite title 7	
Favorite title 8	
Favorite title 9	
Favorite title 10	
...	
Favorite title 20	

 Main menu > Commissioning > Favorite pages > Name datapoints

Favorites 1...Favorites 20

<i>Name of datapoint</i>	<i>User-defined text</i>
Datapoint name 1	
Datapoint name 2	
Datapoint name 3	
Datapoint name 4	
Datapoint name 5	
Datapoint name 6	
Datapoint name 7	
Datapoint name 8	
Datapoint name 9	
Datapoint name 10	

Index

A

abbreviations.....	47
acknowledge faults	42
acknowledgement of faults	42
ACS.....	47
activating communication.....	22
add devices.....	26
adding datapoints to favorite pages.....	28
adding devices.....	26
address assignment manual.....	21
address assignment with the ETS	21
address search	21
area.....	22
assignment of addresses.....	22
automatic address search.....	21

B

backup copy.....	32
bus users	15
business card.....	37
business card line	47

C

central power supply.....	18
commissioning	20
commissioning menu	21
communication.....	22
connection terminals.....	46
contrast of display.....	37
create device list.....	24
creating the device list	24

D

data backup	32, 34
data backup on second unit.....	33
datapoints of favorite pages.....	27
delete all favorite pages.....	31
delete device list	26
delete devices.....	26
delete faults.....	42
delete favorites.....	30
deleting datapoints on favorite pages	30
deleting devices	26
deleting faults.....	42
deleting favorite pages.....	30
deleting the device list.....	26
device address.....	21, 22
device descriptions	7, 16, 43
device information.....	39
device list	23, 38
device list on the main menu	41
display contrast.....	37

display faults	41
display format type of display.....	27
display of bus fault status message	37
display of faults	40
display the device list	27

E

editable text.....	47
editing text.....	47
electrical connections.....	46
entry of text	37
error code list	44
error handling	16, 19, 22, 34
error handling time of day	36
ESC button.....	11
ETS	21
external power supply	18

F

fault button	11
fault history.....	42
fault status message bus	37
faults of non-listed bus users	41
favorite pages.....	38
favorites.....	16, 27
format clock.....	35

H

hardware version.....	39
-----------------------	----

I

info button	11
info level	12
info page	41
information describing what is visible.....	16

K

key features.....	9
-------------------	---

L

language catalogs.....	43
language selection	36
leaving the password level	20
line.....	22
line coupler.....	21
list error	27
list information	27
list of error codes.....	44
local data backup	32
local operation.....	15
long text.....	15
loss of password	38
LTE mode.....	47

M			
manual assignment of addresses.....	21		
memory card	7, 43		
menu tree	12, 13		
N			
name datapoints.....	29		
name devices	25		
name favorites.....	29		
naming datapoints	29		
naming the devices	25		
naming the favorite pages	29		
navigation	15		
non-listed faults	41		
O			
operating elements.....	11		
operating levels	12		
operation	11		
operation of devices	15		
operator unit functions.....	11		
operator units	7		
P			
password level.....	12, 20, 38		
passwords	38		
polarity CE+ / CE-.....	19		
power supply via Konnex bus.....	18		
power supply via Synco controller.....	19		
product documentation.....	8		
product range	15		
programming mode	21, 22		
R			
rectification of errors.....	44		
rectifying errors.....	44		
reset faults.....	42		
resetting faults	42		
restore	33		
S			
safety.....	10		
		second unit for data backup	33
		select-and-press knob	11
		selecting the language.....	20, 36
		service level.....	12, 38
		setting the time of day	35
		S-mode	47
		SNA	47
		software version	39
		sort device list.....	24
		sort favorites	29
		sorting automatically	24
		sorting favorites	29
		sorting manually	24
		sorting the device list	24
		start page.....	12
		state of list	27
		status messages.....	23
		storage date.....	33
		storage year.....	33
		subnetwork address	21
		T	
		text catalog	7
		text entries	37
		time format clock	35
		time of day and date	35
		time of day error handling.....	36
		time-of-day format	35
		time-of-day setting	35
		topology	8
		type of device	39
		type of memory card.....	39
		U	
		unit of temperature	37
		user level	12, 38
		user-defined text.....	17
		V	
		VVS	47

Siemens Switzerland Ltd
Building Technologies Group
International Headquarters
HVAC Products
Gubelstrasse 22
CH- 6301 Zug
Tel. +41 41 724 24 24
Fax +41 724 35 22
www.sbt.siemens.com

© 2006 Siemens Switzerland Ltd
Subject to alteration